

REV.	DESCRIPTION	DATE

NOTE:

- A. Material:
 1. Housing : HTN , UL94V-0.
 2. Terminal : Copper Alloy .

- B. Plating:
 1. Terminal : Plating is based on 50u" Nickel under plating,
 Selective Gold plated in contact area,
 Solder tail 100u" min Sn over Nickel plated.

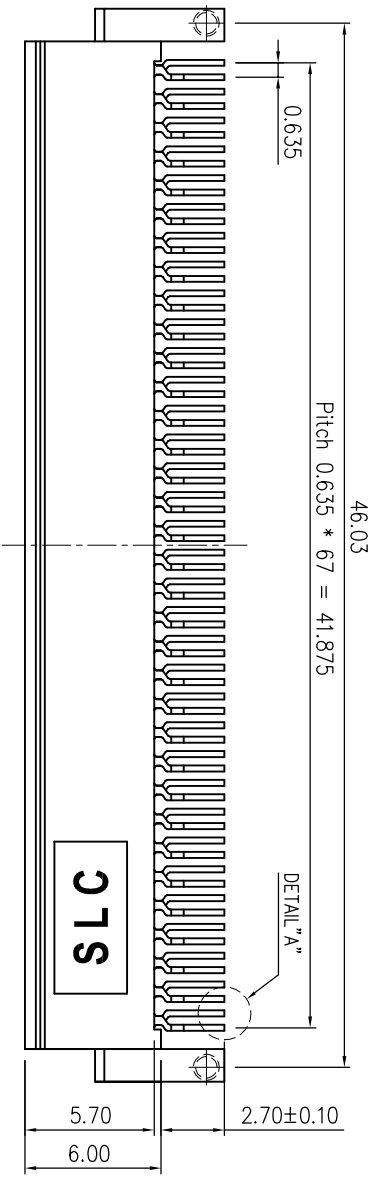

DETAIL "A" 10:1

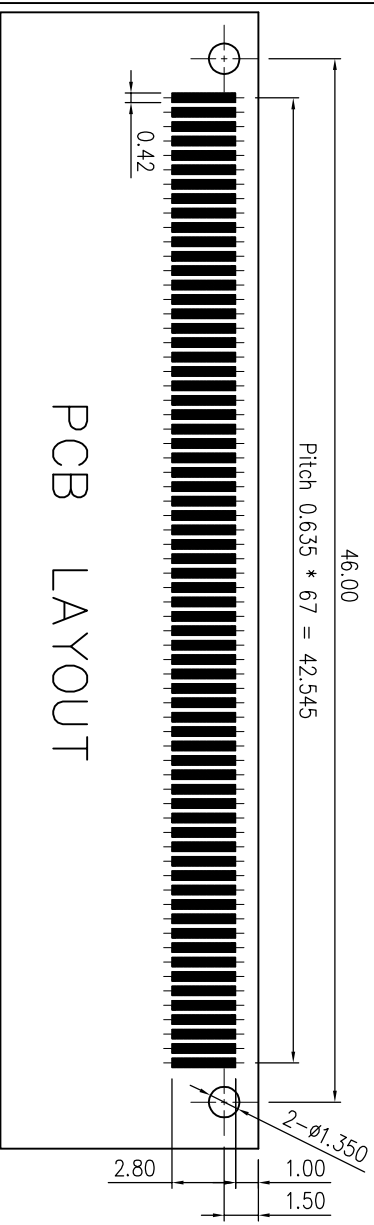
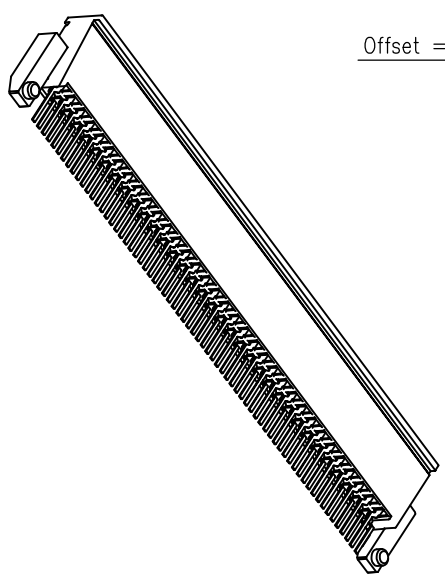
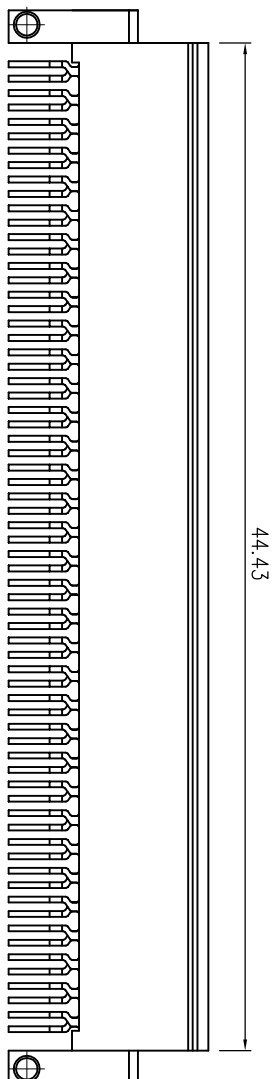
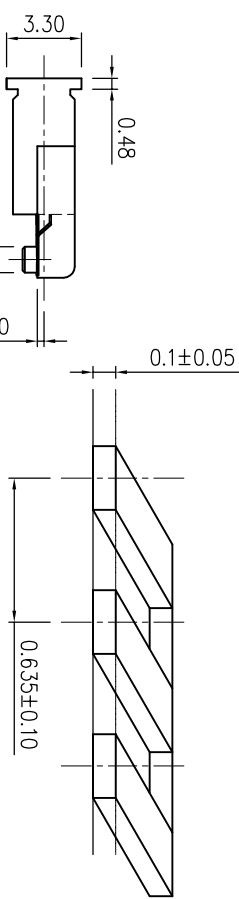
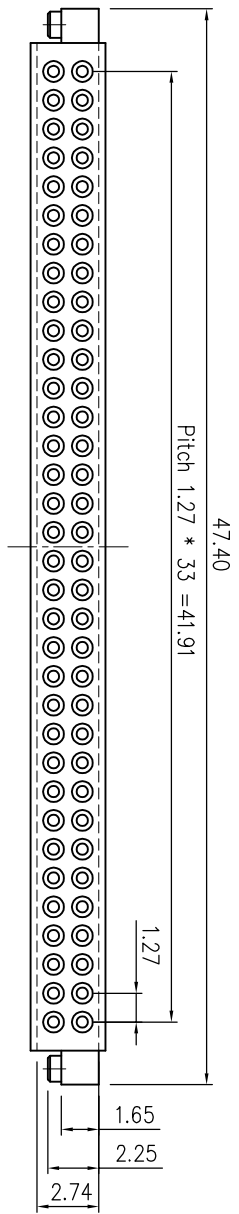

TOLERANCE .X ±0.250 .XX ±0.100 .XXX±0.050	DRAWER <i>Chun Chuan Sui</i>	NAME SunLight 日亮電子科技有限公司 <i>Sun-Light Electronic Technologies Inc</i>
	CHECK <i>Shi Tsung Sui</i>	
UNITS : mm	DESIGNED <i>Chun Chuan Sui</i>	PART NO. 8690-S3B68X-0
	APPROVAL <i>Shue Tsung Sui</i>	
SCALE 3 : 1	DATE 05 / 24 / 2002	DRAW NO. 8690-S3B68X
SIZE A4	SHEET 1 OF 1	REV. A